

www.aheadtank.com 337.330.4407
Broussard, LA USA 70518

AT-35STP-D
PERSPECTIVES

DRAFTED BY: In-house

SCALE:
NTS

SUBMITTED DATE:
12-15-25

SHEET NO:
1 of 4

REV. C

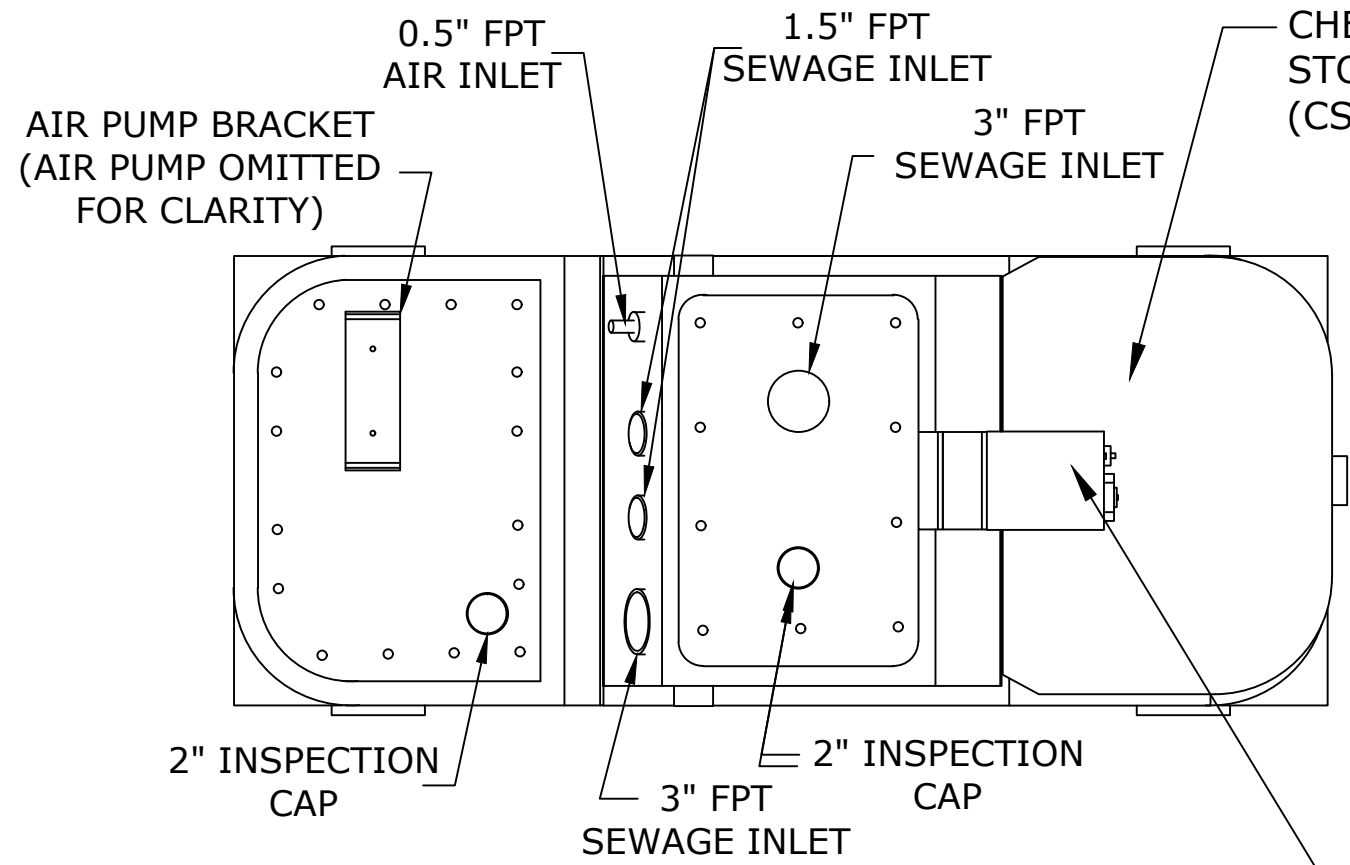

TOP

CHEMICAL INJECTION METERING PUMP (CIMP)

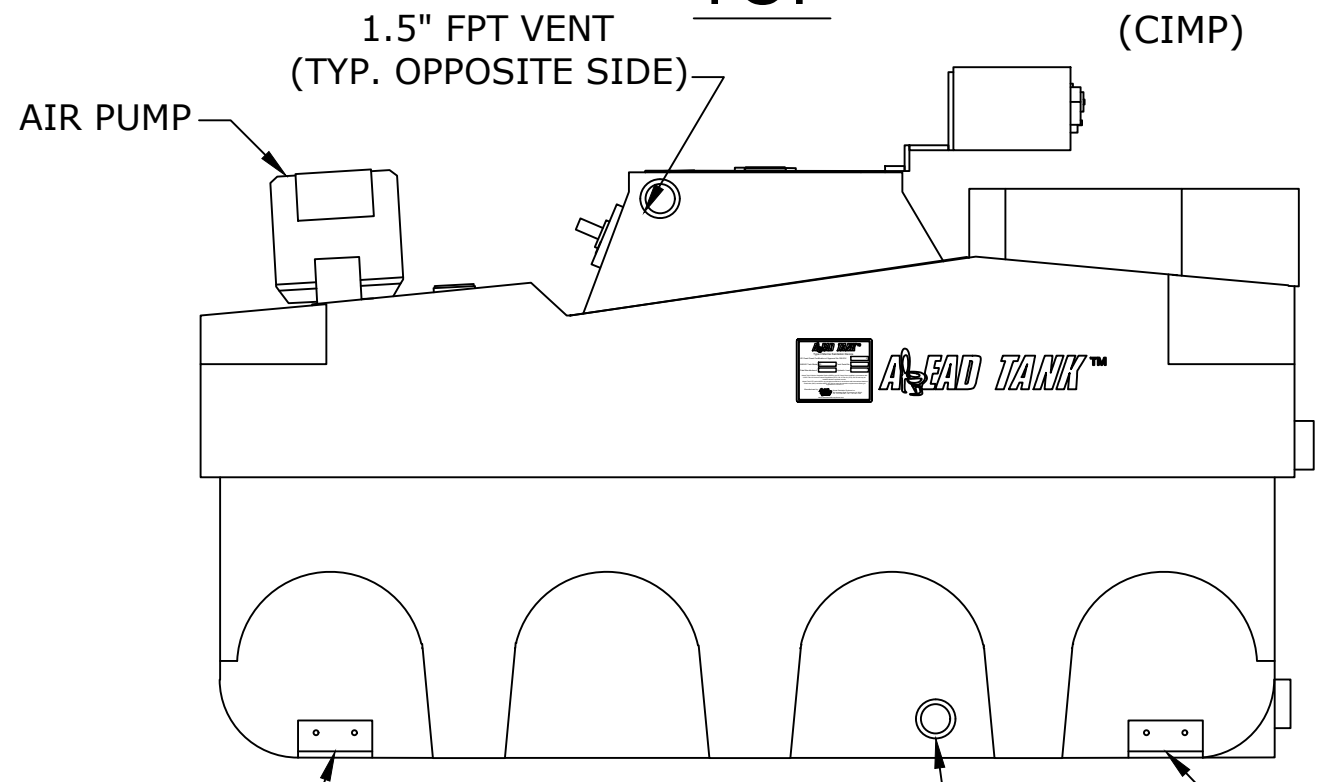
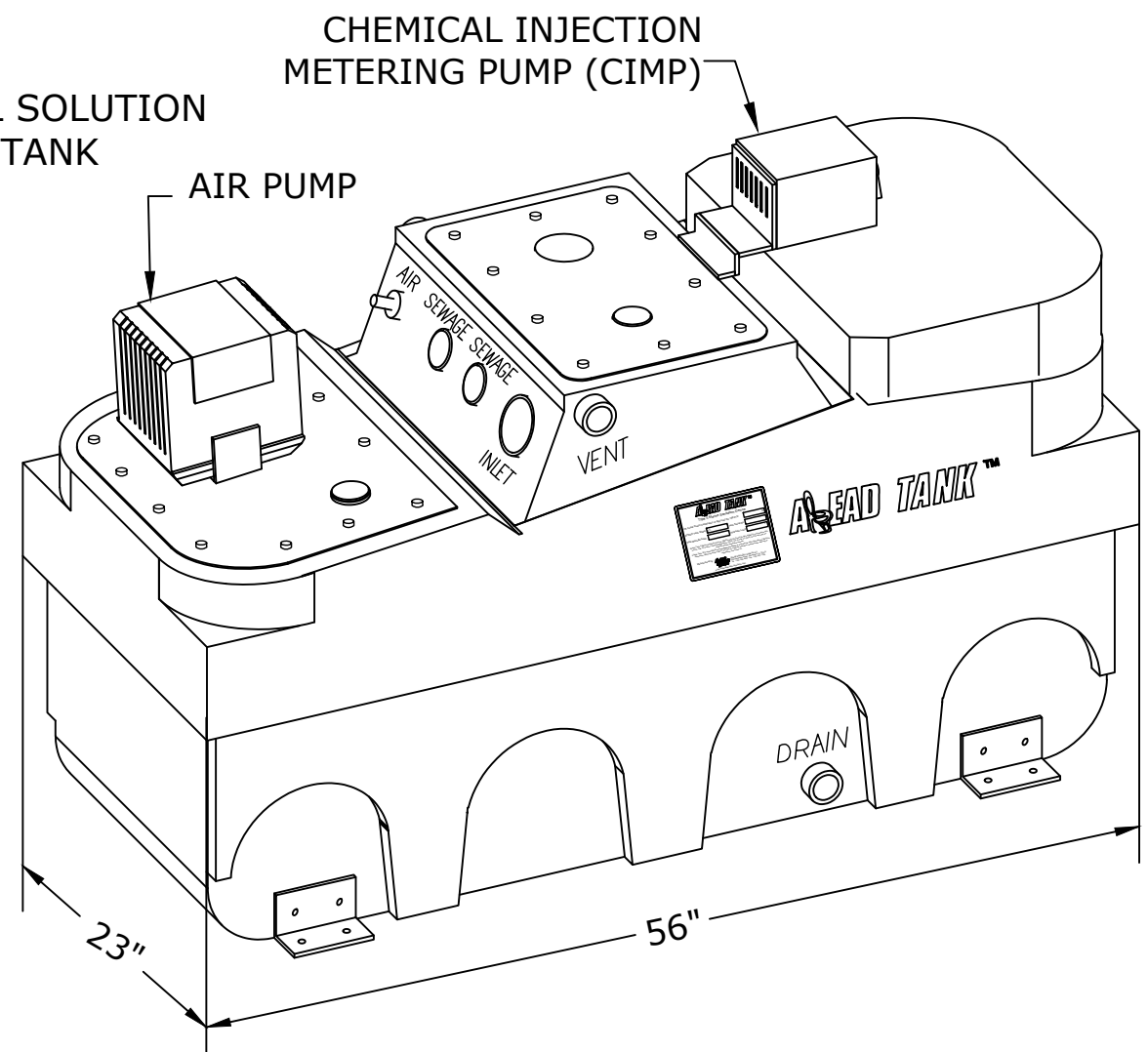

SIDE

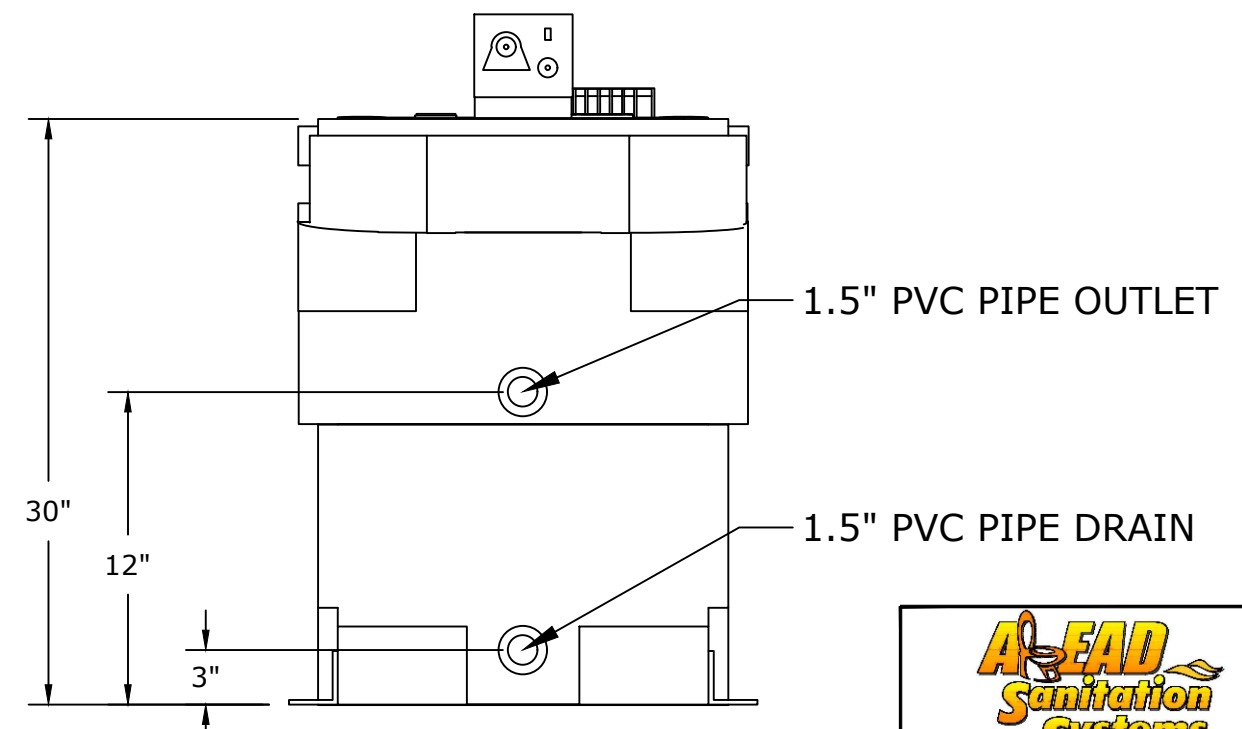

BACK



www.aheadtank.com 337.330.4407
Broussard, LA USA 70518

AT-35STP-D
PLAN & ELEVATION VIEWS

DRAFTED BY: In-house	SCALE: NTS
SUBMITTED DATE: 12-15-25	SHEET NO: 2 of 4
	REV. C

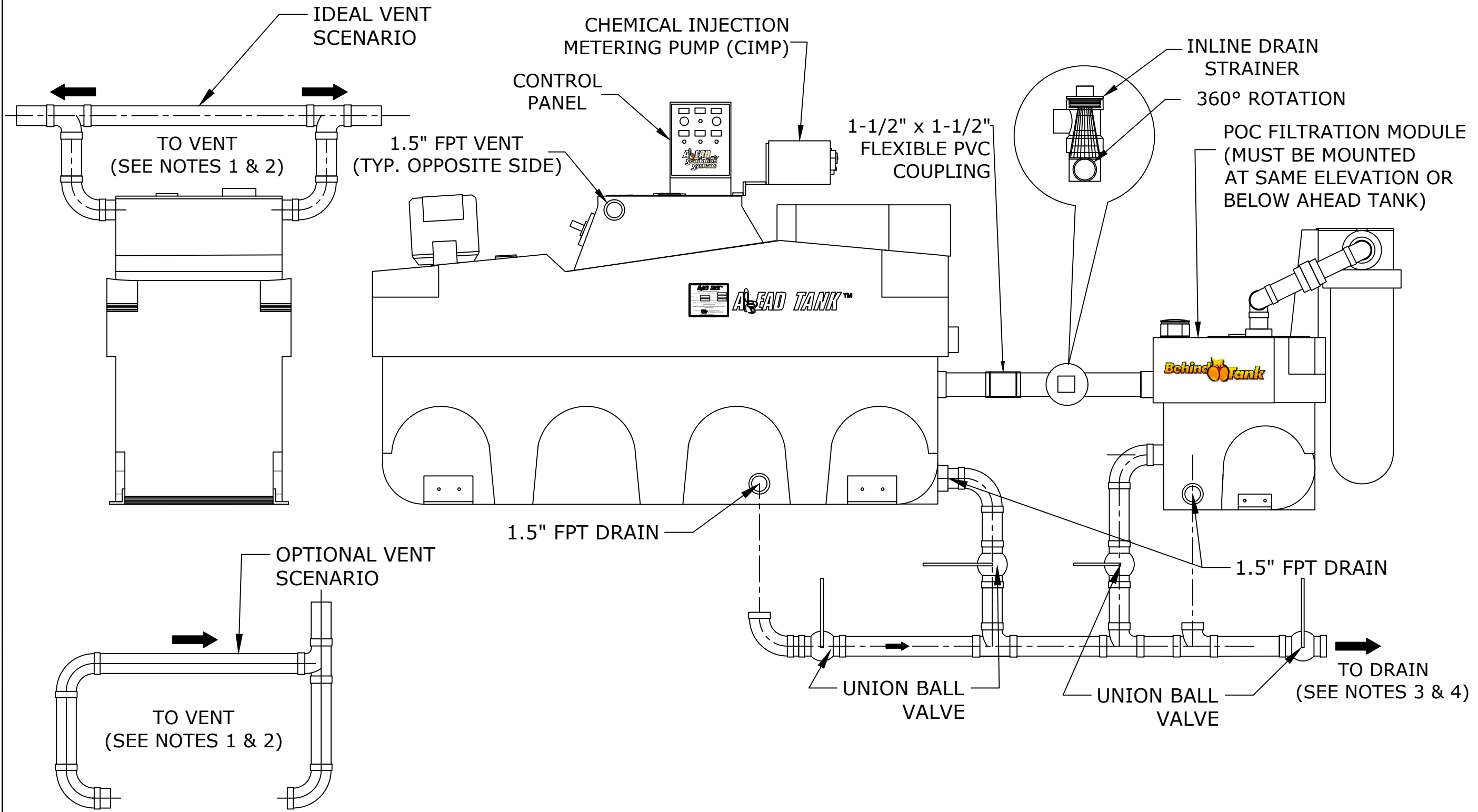

NOTES:

1. VENT PLUMBING NOT INCLUDED. LONG SWEEP ELBOWS MUST BE USED.
2. VENTS ON BOTH SIDES OF THE AHEAD TANK MUST BE PLUMBED TO VENT UP AND OUT, WITHOUT LOOPS OR SAGS.
3. DRAIN PLUMBING NOT INCLUDED. LONG SWEEP ELBOWS MUST BE USED.
4. SANITARY TEES MUST BE USED, WITH THE BRANCH SWEEPING TOWARD DRAIN EXIT.



www.aheadtank.com 337.330.4407
Broussard, LA USA 70518

AT-35STP-D
TYP. DRAIN MANIFOLD W/POC

DRAFTED BY: In-house	SCALE: NTS
SUBMITTED DATE: 12-15-25	SHEET NO: 3 of 4

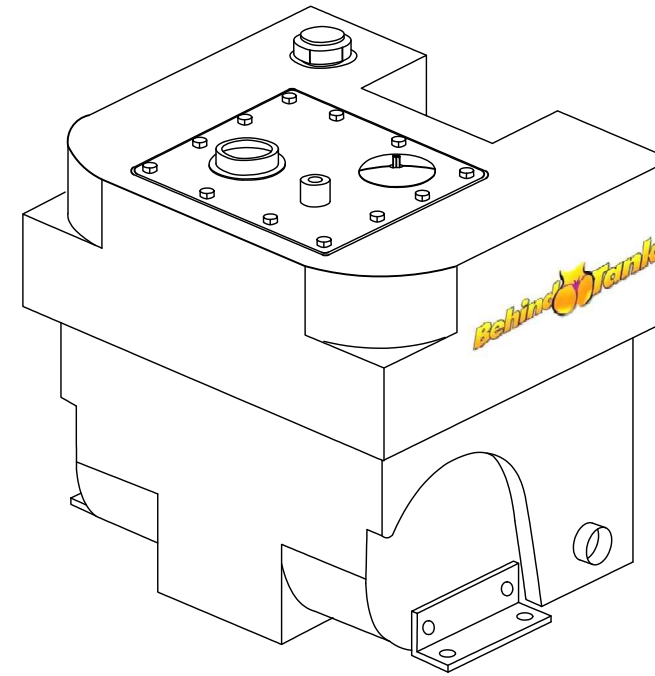
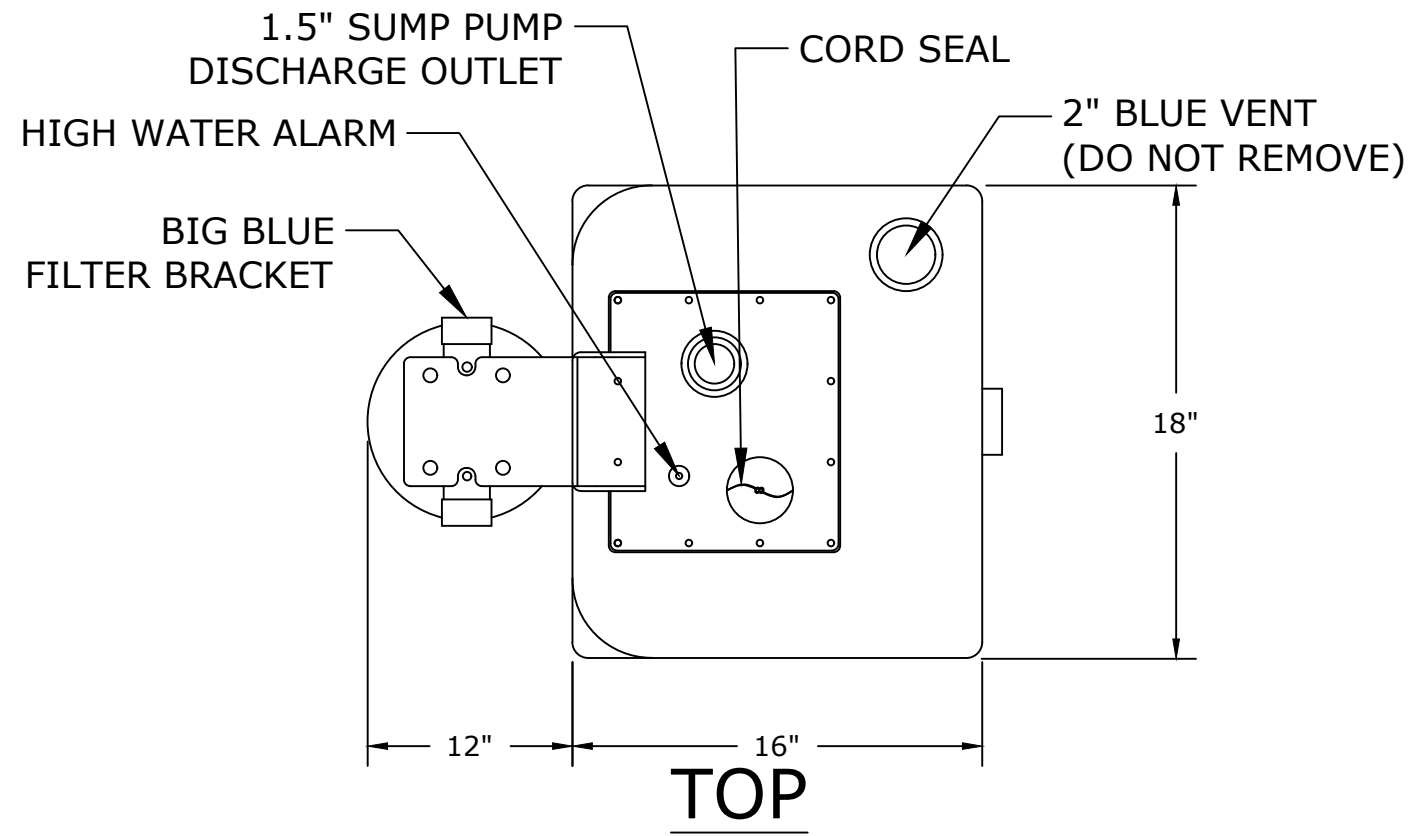

NOTE:
POC BLUE FILTER
NOT SHOWN THIS VIEW.

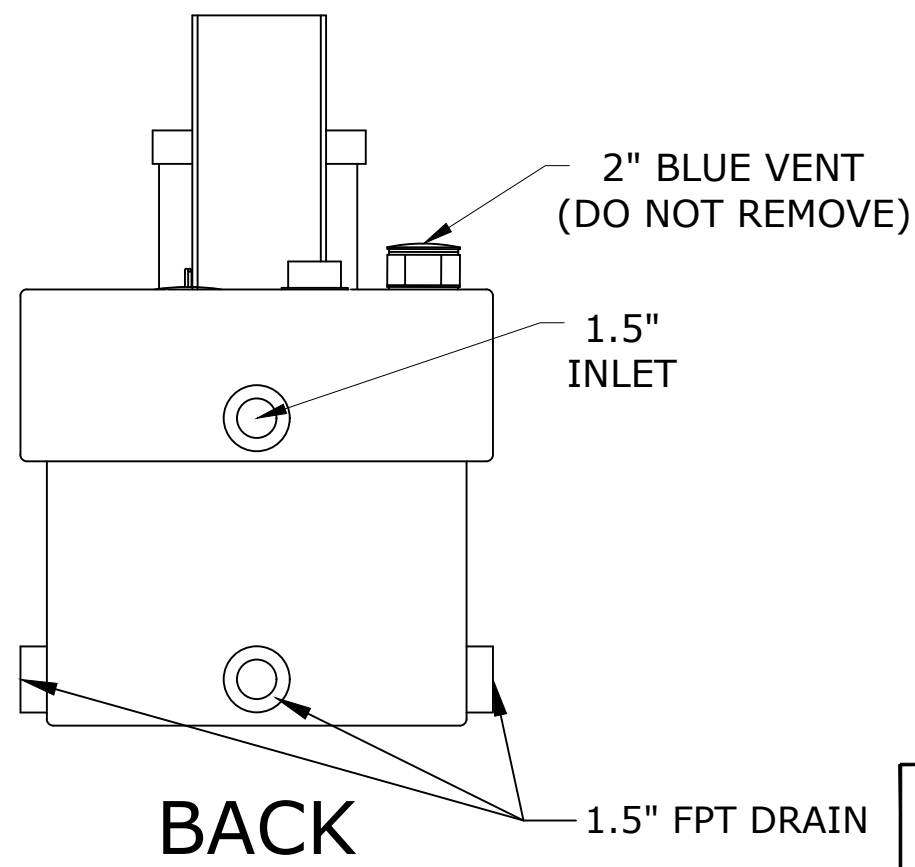
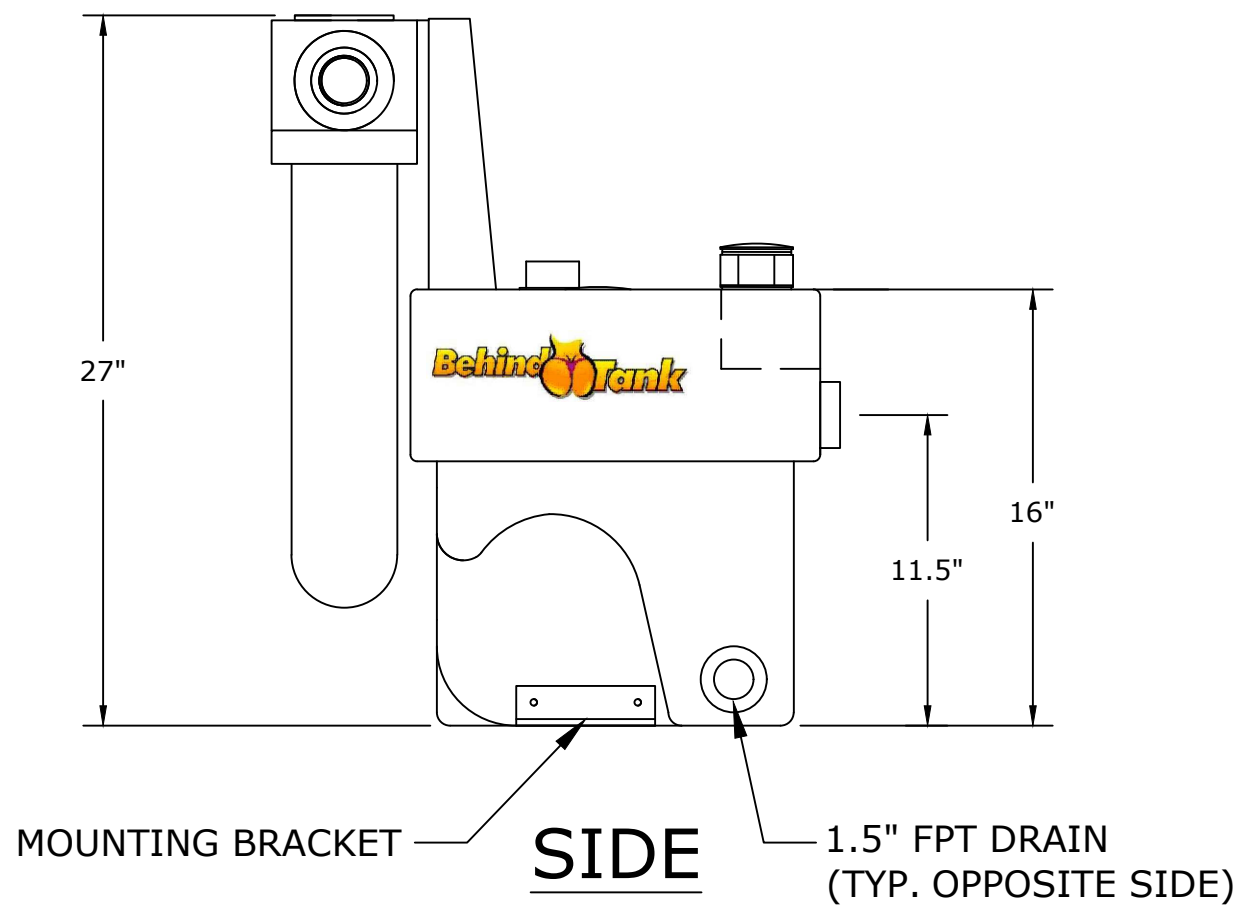

NOTES:

1. PLUMB ONLY ONE DRAIN ON POC MODULE.
2. USE PROVIDED YELLOW THREADED CAPS TO CLOSE OFF UNUSED DRAINS.



www.aheadtank.com 337.330.4407
Broussard, LA USA 70518

AT-35STP-D
POC FILTRATION MODULE

DRAFTED BY: In-house	SCALE: NTS
SUBMITTED DATE: 12-15-25	SHEET NO: 4 of 4
	REV. C